

Sichuan Nigale Biotechnology Co., Ltd.
No. 28 Kuixing Road 641400 Jianyang, Sichuan,
PEOPLE'S REPUBLIC OF CHINA



NIGALE

SCIENCE IN BLOOD
THE PURSUIT OF NIGALE

About Nigale

01

Quality System

03

Product Category

06

- Blood Component Separator
- Disposable Blood Component Apheresis Set
- Plasma Separator
- Disposable Plasma Apheresis Set
- Therapeutic Plasma Exchange (TPE) System
- Blood Cell Processor

CONTENTS

C

Nigale and the Team



The only manufacturer licensed to produce full lines of blood collection and transfusion devices and disposable kits in China

A pioneer of application technologies of blood transfusion medicine in China

A business enterprise with patents in high and new technologies and inventions

One of NIGALE's Plants



ABOUT NIGALE

Nigale was founded in September 1994. Nigale provides comprehensive portfolio of blood transfusion and collection devices, disposables, solution, and software system with customization service.

Started to export in 2008

Employees: 1000

Located in Chengdu / Sichuan Province

3 factories (1 under construction)

Focusing on:

One field: blood transfusion industry

Three product categories: Device, Disposables, Software/Service

Three markets: Plasma Centers, Blood Centers/Banks and Hospitals

EU Rep.: Shanghai International Holding Corp. GmbH, Hamburg

CERTIFICATES

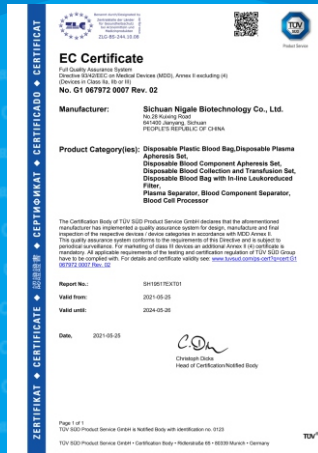

Certificate of CE



Certificate of ISO 13485



Certificate of GMP

WHY CHOOSE NIGALE?

Reliable Quality
 Reasonable Cost
 Personalized Service



SICHUAN NIGALE
BIOTECHNOLOGY CO., LTD.

Product Catalogue

Equipment
Disposables
Protocols



NIGALE





DigiPla 80 Plasma Separator



- Advanced optical sensor and control system
- Wide touch screen with multi-languages
- Barcode scanner available
- Perfect sound and light alarm system
- Suitable for bag and bottle kits
- Bi-directional transmission function available
- Anticoagulant(AC)weigher control function available

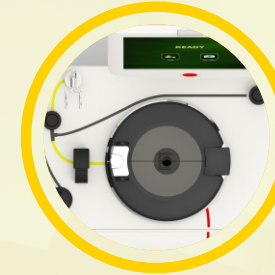

ORDER INFORMATION

Item Code	DigiPla80
Package	1 Pcs/Carton
Ctn Size	630x540x720
Weight	35kg/Carton

Disposable & Solution Plasma

Disposable Plasma Apheresis Set



- One-arm procedure
- Fully closed system prevents contamination effectively
- Pre-assembled kit saves time and cost

**Disposable
Plasma**

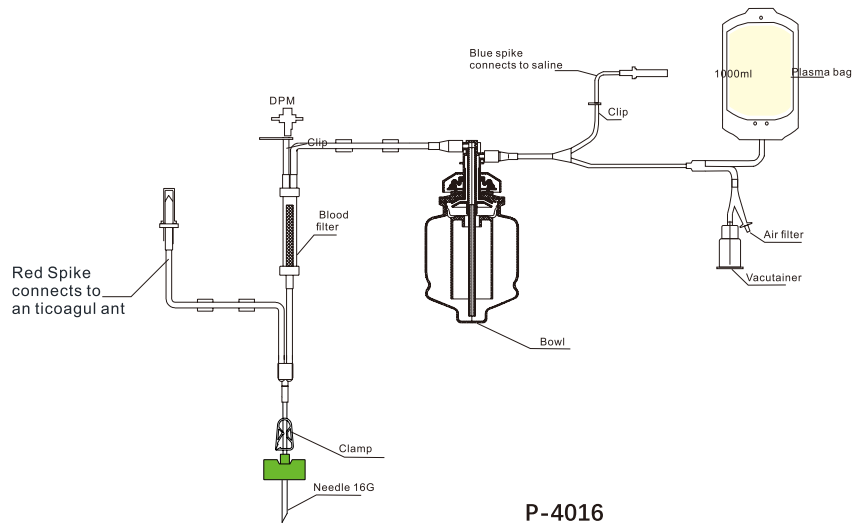

ORDER INFORMATION

Item Code	P-4016
Pre-assembled	Bowl, Tubing, Plasma bag & Needle(option)
Package	25 Sets/Carton
Ctn Size	575*515*220 (mm)
Weight	13 kg/Carton

Other models available

Anticoagulant (4%, 200ml)

Package	50 Bags/Carton
Ctn Size	380×260×220 (mm)
Weight	12 kg/Carton (4%, 160ml,180ml,available)

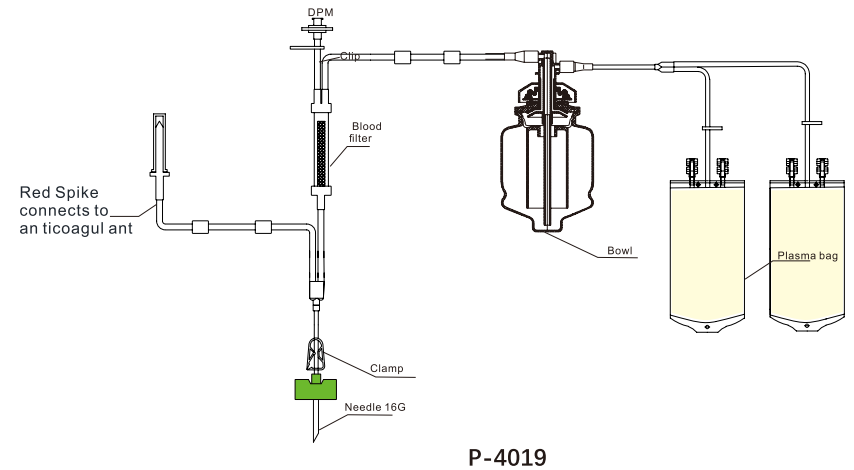

ORDER INFORMATION

Item Code	P-4019
Pre-assembled	Bowl, Tubing, Plasma bag&Needle
Package	25 Sets/Carton
Ctn Size	575*515*220 (mm)
Weight	9.5kg/Carton

Saline (0.9%, 250ml)

Package	40 Bags/Carton
Ctn Size	400*300*200 (mm)
Weight	12 kg/Carton (0.9%,500ml,1000ml available)

Device
Platelets

NGL XCF 3000
Blood Component Separator



- Comprehensive error and diagnostic messages
- Easy-to-read touch screen
- Donor-dependent return flow rates for optimal donor comfort
- Leakage detector inside the centrifuge
- Single needle mode, simple operation and minimal training required
- Ideal for mobile collection and for centers with restricted space
- Double units leukoreduced platelet apheresis protocol available
- Therapeutic Plasma Exchange protocol available
- Automated processing cycle with stream-line operation

ORDER INFORMATION

Item Code	NGL XCF 3000
Dimensions	720x500x638 (mm)
Power Rating	≤500VA
Voltage	220V+/-10% (110V,60 Hz available)
Frequency	50Hz
Weight	42kg
Protocol Options	Platelet Apheresis/Therapeutic Plasma Exchange(TPE)
Closed Disposable Sets	P-2000 IA/B/C/D/E/F/G
Language	Ask Nigale for available languages



Disposable Blood Component Apheresis Set



Applications

Collection of platelet

Machines compatible

P-2000 IA/B/C/D/E/F/G: NGL XCF 3000

Main features and advantages

Fully closed system: eliminating contamination effectively

High quality platelet

Cost savings: capable of harvesting two units of platelet from a single donor

ORDER INFORMATION

Item Code	P-2000 IE	ACD-A (200mm)
Package	8 Sets/Carton	50 Bags/Carton
Ctn Size	525x385x450 (mm)	380x260x220 (mm)
Weight	7.8 kg/Carton	12 kg/Carton
	Other models available	

Disposable Platelets Solution

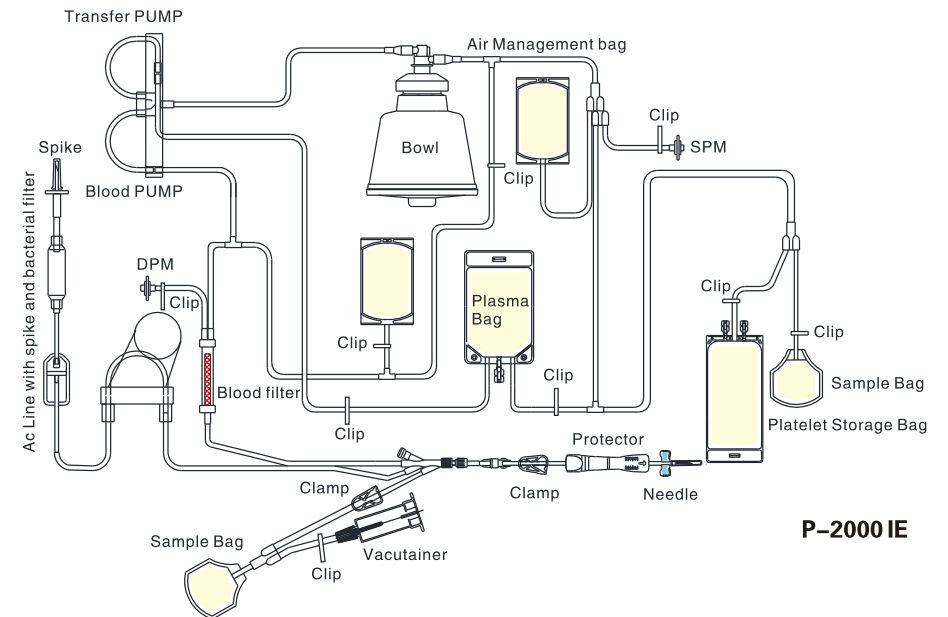

Therapeutic Plasma Exchange (TPE) System



System

Plasma Separator DigiPla 90
Disposable Plasma Apheresis Set

Application

TPE Therapy

Advantages

Fully closed system
Filtration design, returns safely
Pre-assembled kit, easy to use
High quality needle with very sharp tip

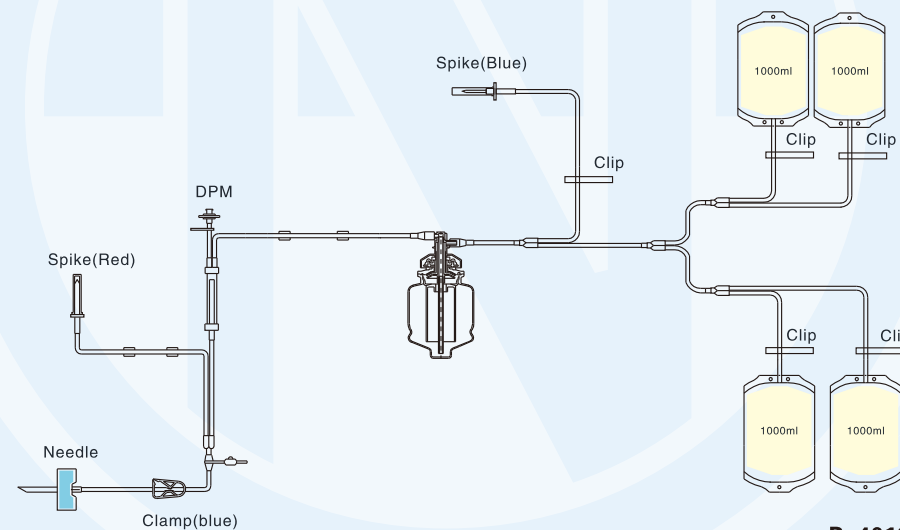

P-4018

ORDER INFORMATION

Item Code	P-4018		
Pre-assembled	Bowl, Tubing, PLM Bag & Needle		
Package	25 Sets/Carton		
Ctn Size	575x515x220 (mm)		
Weight	12,16 kg/Carton		
Anticoagulant		Saline	
Spec	4%, 200ml	Spec	0.9%, 250ml
Package	50 Bags/Carton	Package	40 Bag/Ctn
Ctn Size	380×260×220 (mm)	Ctn Size	400×300×200 (mm)
Weight	12 kg/Carton	Weight	12 kg/Carton

BBS 926
Blood Cell Processor



- Automatic adding glycerin, deglycerizing and washing of fresh red blood cells.
- Automatic setting the 1unit, 1.5 units and 2units without having to manually adjust parameters
- Big touch screen
- Equipped with unique 360 degree medical double axis vibrator reduce the impact on cell
- Full parameter settings, suitable for different clinical requirements
- Liquid injection speed can be adjusted according to the operator's needs
- Perfect design and built-in self-diagnosis centrifuge discharge detection, real-time monitor for centrifugal separation and washing

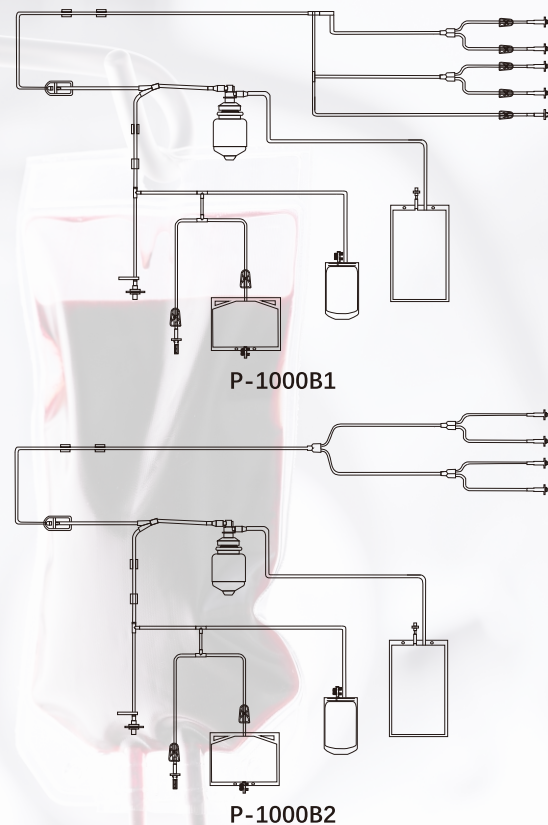

ORDER INFORMATION

Item Code	BBS926	Closed Disposable Sets	P-1000B1/B2
Dimensions	720x500x640 (mm)	Pre-assembled	Bowl, tubing and bags
Power Rating	≤500VA	Package	10 Sets/Carton
Voltage	220VAC+/- 5%	Ctn Size	530x370x500(mm)
Frequency	50Hz	Weight	9.2 kg/Carton
Weight	37kg		
Protocol Portfolio	Ask Nigale for available languages		

NIGALE'S PROMISE



New customer on-site training

24 hrs quick response

Regular follow-up by engineer

One year free maintenance after purchase

Internet support



SICHUAN NIGALE BIOTECHNOLOGY CO., LTD.



Proprietary Rights / Disclaimer

All description or information contained in these brochures may not be released and reproduced to any of the general public without written consent of Nigale. The author reserves the right not to be responsible for the correctness, completeness or quality of the information provided. Liability claims including any sort of information which is incomplete or incorrect, will therefore be rejected.

Parts of the pages might be extended, changed or partly or completely deleted by the author without separate announcement.



Website: <http://nigale.en.alibaba.com>

<http://www.ngl-tech.com>

Technical Support: david@ngl-cn.com

Purchase Support: nicole@ngl-cn.com

NIGALE

